

# ICC-ES Evaluation Report

ESR-2269

Reissued February 2025

This report also contains:

- [City of LA Supplement](#)

Subject to renewal February 2027

- [FL Supplement w/HVHZ](#)

ICC-ES Evaluation Reports are not to be construed as representing aesthetics or any other attributes not specifically addressed, nor are they to be construed as an endorsement of the subject of the report or a recommendation for its use. There is no warranty by ICC Evaluation Service, LLC, express or implied, as to any finding or other matter in this report, or as to any product covered by the report.

Copyright © 2025 ICC Evaluation Service, LLC. All rights reserved.

<p><b>DIVISION: 03 00 00— CONCRETE</b></p> <p><b>Section: 03 15 00— Concrete Accessories</b></p> <p><b>Section: 03 16 00— Concrete Anchors</b></p> <p><b>DIVISION: 04 00 00— MASONRY</b></p> <p><b>Section: 04 05 19.16— Masonry Anchors</b></p> <p><b>DIVISION: 05 00 00— METALS</b></p> <p><b>Section: 05 05 23— Metal Fastenings</b></p> <p><b>DIVISION: 06 00 00— WOOD, PLASTICS AND COMPOSITES</b></p> <p><b>Section: 06 05 23— Wood, Plastic, and Composite Fastenings</b></p>	<p><b>REPORT HOLDER: HILTI, INC.</b></p>	<p><b>EVALUATION SUBJECT: HILTI LOW-VELOCITY X- U AND X-U 15 UNIVERSAL FASTENERS AND X-P CONCRETE FASTENERS</b></p>	
--	--	---	---

## 1.0 EVALUATION SCOPE

Compliance with the following codes:

- 2024, 2021, 2018 and 2015 [International Building Code® \(IBC\)](#)
- 2024, 2021, 2018 and 2015 [International Residential Code® \(IRC\)](#)

Section number references in this report are for the 2024 IBC and IRC and the standards referenced therein. Corresponding section numbers for earlier code editions are shown in [Table 7](#) at the end of this report.

Property evaluated:

Structural

## 2.0 USES

### 2.1 General:

The Hilti X-U and X-P power-actuated fasteners (PAFs) are used to attach wood, light gage steel, and other building elements to base materials of normalweight concrete, sand-lightweight concrete, steel deck panels with sand-lightweight concrete fill and concrete masonry. The X-U fasteners are also used to attach building elements to steel base materials. The Hilti X-U 15 fasteners are used to attach light gage steel and other building elements to steel base material. The fasteners are alternatives to the cast-in-place anchors described

in IBC Section 1901.3 for placement in concrete; the embedded anchors described in Section 8.1.4 of TMS 402, referenced in Section 2107 of the IBC for placement in masonry; and the welds and bolts used in the steel connections, described in IBC Section 2201.4. For structures regulated under the IRC, the fasteners may be used where an engineered design is submitted in accordance with IRC Section R301.1.3.

The PAFs are intended for use in redundant applications, which are defined as applications where multiple PAFs support elements that are capable of redistributing the load to neighboring PAFs, in the event of a PAF failure. Examples include, but are not limited to, PAFs used to fasten cold-formed steel track, where the track can redistribute loads; and PAF assemblies where the supported elements, such as conduit and ceiling framing can redistribute the loads to neighboring PAF assemblies.

## 2.2 Horizontal Diaphragms:

The Hilti X-U fasteners may be used as alternates to 10d common nails for fastening wood structural panels to structural steel members in sheathed horizontal diaphragms.

## 3.0 DESCRIPTION

### 3.1 Fasteners:

**3.1.1 X-U:** The X-U fasteners are powder-driven fasteners made from hardened steel complying with the manufacturer's quality documentation, austempered to a Rockwell C nominal hardness of 57.5 and zinc-plated in accordance with ASTM B633 SC 1, Type III. The fasteners have a shank diameter of 0.157 inch (4.0 mm), a head diameter of 0.32 inch (8.2 mm) and a knurled tip, and come in lengths ranging from 0.63 inch to 2.83 inches (16 to 72 mm). See [Figure 1](#) for the fastener configuration.

**3.1.2 X-U 15:** The X-U 15 fasteners are powder-driven fasteners made from hardened steel complying with the manufacturer's quality documentation, austempered to a Rockwell C nominal hardness of 59 and zinc plated in accordance with ASTM B633 SC 1, Type III. The fasteners have a shank diameter of 0.145 inch (3.7 mm), a head diameter of 0.32 inch (8.2 mm) and a shank length of 0.63 inch (16 mm). See [Figure 2](#) for the fastener configuration.

**3.1.3 X-P:** The X-P fasteners are powder-driven fasteners made from hardened steel complying with the manufacturer's quality documentation, austempered to a Rockwell C nominal hardness of 59 and zinc plated in accordance with ASTM B633 SC 1, Type III. The fasteners have a shank diameter of 0.157 inch (4.0 mm), a head diameter of 0.32 inch (8.2 mm) and come in lengths ranging from 0.87 inch to 1.57 inches (22 to 40 mm). See [Figure 3](#) for the fastener configuration.

### 3.2 Substrate Materials:

**3.2.1 Concrete:** Normal-weight and sand-lightweight concrete must comply with IBC Chapter 19 or IRC Section R402.2, as applicable. The minimum concrete compressive strength at the time of fastener installation must be as noted in the applicable allowable load table. Hollow core precast concrete slabs must conform to the cross-sectional dimensions shown in [Figure 7](#).

**3.2.2 Concrete Masonry:** Concrete masonry units (CMUs) must be minimum 8-inch-thick (203 mm), and must comply with ASTM C90. Mortar must comply with ASTM C270. Grout must be coarse grout complying with ASTM C476. Concrete masonry walls must have a minimum compressive strength,  $f_m$ , of 1,500 psi (10.3 MPa). See [Table 6](#) for applicable CMU density and mortar type.

**3.2.3 Steel:** Structural steel must comply with the minimum strength requirements of ASTM A36, ASTM A572 Grade 50 or ASTM A992, as applicable, and must have minimum yield and tensile strengths and thickness as noted in [Table 2](#).

**3.2.4 Steel Deck Panels:** Steel deck panel properties and configurations must be as described in [Table 5](#) and [Figures 4](#) through [6](#), as applicable.

### 3.3 Wood Structural Panel Horizontal Diaphragms:

**3.3.1 Wood Structural Panel:** Wood structural panels must have a minimum thickness of  $1\frac{5}{32}$  inch (11.9 mm) and must comply with the requirements of Section 4.2.7 of the 2021 AWC Special Design Provisions for Wind & Seismic (SDPWS), which is referenced in IBC Section 2305.

**3.3.2 Structural Steel Supports:** Structural steel framing members supporting the wood structural panel diaphragm must comply with the minimum strength requirements of ASTM A36, ASTM A572 Grade 50 or ASTM A992, and have a thickness greater than or equal to  $\frac{3}{16}$  inch (4.8 mm) as shown in [Table 2](#).

## 4.0 DESIGN AND INSTALLATION

### 4.1 Design:

**4.1.1 General:** Design of the connection of attached material to the base material must take into account the properties of the attached material and the need for redundancy, and must comply with the applicable requirements of the IBC.

Selection of fasteners must take into consideration the applicable base material and the length of the fastener. The minimum fastener length must be determined as follows:

- Unless otherwise noted, for installation into concrete, concrete-filled steel deck panels, concrete masonry and steel base materials, the minimum effective shank length shown in [Table 1](#) must equal or exceed the sum of the thickness of the attached material and the minimum embedment depth (penetration) shown in the applicable tables in this report.
- For installation through steel base materials, the minimum effective shank length shown in [Table 1](#) must equal or exceed the sum of the following: the thickness of the attached material, the thickness of the base material and the required point penetration shown in the applicable tables in this report.

**4.1.2 Allowable Loads for Individual Fasteners:** The applicable allowable shear and tension load tables for the Hilti X-U, X-U 15 and X-P fasteners driven into different base materials may be determined by referencing [Table 1](#).

The most critical applied loads, excluding seismic load effects, resulting from the load combinations in Section 2.4 of ASCE 7 (referenced in IBC Section 1605.1) or IBC Section 1605.2 must not exceed the allowable loads. For fasteners which are subjected to seismic loads, see Section 4.1.7 for additional information. The stress increases and load reductions described in IBC Section 1605.2 are not allowed.

Allowable shear and tension loads in this report apply to the connection of the fastener to the base material only. Other limit states applicable to the design of a connection, such as fastener pull-through (pull-over) and lateral bearing on the attached material, which are governed by the properties of attached materials, are outside the scope of this report. Design of the connection to the attached material must comply with the applicable requirements of the IBC.

**4.1.3 Allowable Loads for Connections of Wood Members to Supporting Material:** When designing the connection of wood members to the base material, the bending yield strength of the PAFs can be assumed to be the same as that of a nail with the same shank diameter. Allowable fastener head pull-through must be determined in accordance with Sections 12.2.5 and 11.3 of the ANSI/AWC National Design Specification for Wood Construction® (NDS). Minimum fastener spacing, edge and end distance in the wood must be as required by the NDS to prevent splitting of the wood.

**4.1.4 Combined Loading:** For fasteners subjected to both shear and tension loads, compliance with the following interaction equation must be verified:

$$(p/P_a) + (v/V_a) \leq 1$$

where:

- p = Actual applied tension load on fastener, lbf (N).
- P<sub>a</sub> = Allowable tension load for the fastener, lbf (N).
- v = Actual applied shear load on fastener, lbf (N).
- V<sub>a</sub> = Allowable shear load for the fastener, lbf (N).

**4.1.5 Wood Structural Panel Horizontal Diaphragms:** When the X-U fastener is used to fasten wood structural panels to steel members, the fastener is equivalent to a 10d common nail specified in Table 4.2A of AWC SDPWS. Diaphragm design, including fastener spacing, diaphragm capacity and diaphragm deflection, must comply with Section 4.2 of AWC SDPWS, which is referenced in IBC Sections 2305.1 and 2306.2.

**4.1.6 Steel-to-steel Connections:** When the Hilti fasteners listed in [Table 2](#) are used in connections of two steel elements in accordance with Section J5 of AISI S100, connection capacity must be determined in accordance with Sections 4.1.6.1 and 4.1.6.2, as applicable.

**4.1.6.1 Connection Strength - Tension:** To determine tensile connection strength in accordance with Section J5.2 of AISI S100, the fastener tension strength, pull-out strength and pull-over strength must be known. These characteristics must be determined as follows:

- **Pull-out Strength:** See [Table 2](#) for available pull-out strength.
- **Pull-over Strength:** The available pull-over strengths must be calculated in accordance with Section J5.2.3 of AISI S100.
- **PAF Tensile Strength:** The allowable fastener tension strengths, determined in accordance with Section J5.2.1 of AISI S100, exceed the corresponding allowable pull-out strengths in [Table 2](#).

**4.1.6.2 Connection Strength - Shear:** To determine shear connection strength in accordance with Section J5.3 of AISI S100, the fastener shear strength, bearing and tilting strength, pull-out strength in shear, net section rupture strength and shear strength limited by edge distance must be known. These characteristics must be determined as follows:

- **Bearing and Tilting Strength:** The available bearing and tilting strengths must be calculated in accordance with Section J5.3.2 of AISI S100.
- **Pull-out Strength in Shear:** The available pull-out strength in shear must be the applicable allowable shear strength from [Table 2](#), or must be calculated in accordance with Section J5.3.3 of AISI S100.
- **Net Section Rupture Strength and Shear Strength Limited by Edge Distance:** The net section rupture strength must be determined in accordance with Section J5.3.4 of AISI S100 and the shear strength limited by edge distance must be determined in accordance with Section J5.3.5 of AISI S100.
- **PAF Shear Strength:** The allowable fastener shear strengths, determined in accordance with Section J5.3.1 of AISI S100, exceed the corresponding allowable pull-out in shear strengths in [Table 2](#).

**4.1.7 Seismic Considerations:** The Hilti fasteners may be used when subjected to seismic loads as follows:

1. The Hilti fasteners may be used for attachment of nonstructural components listed in Table 13.1-1 of ASCE 7, which are exempt from the requirements of ASCE 7.
2. The Hilti fasteners installed in concrete may be used to support acoustical tile or lay-in panel suspended ceiling systems, distributed systems and distribution systems where the service load on any individual fastener does not exceed 90 lbf (400 N).
3. For interior, nonstructural walls that are not subject to sustained tension loads and are not a bracing application, the PAFs may be used to attach steel track to concrete or steel in all Seismic Design Categories. In Seismic Design Categories D, E, and F, the allowable shear load due to transverse pressure shall be no more than 90 pounds (400 N) when attaching to concrete; and no more than the applicable allowable load shown for the Hilti X-U and X-U 15 fasteners in [Table 2](#) when attaching to steel. Substantiating calculations shall be submitted to the code official addressing the fastener-to-base-material connection capacity and the fastener-to-attached-material connection capacity. Interior nonstructural walls are limited to locations where bearing walls, shear walls or braced walls are not required by the approved plans. The design load on the fastener must not exceed the allowable load established in this report for the concrete or steel base material, as applicable.
4. The Hilti X-U and X-U 15 fasteners may be used in conjunction with wood structural panel diaphragms in accordance with Sections 3.3, 4.1.5 and 4.2.8.
5. For Hilti X-U and X-U 15 fasteners installed in steel base materials, the most critical load applied to each individual fastener must be determined from the applicable equations in Section 2.4 of ASCE 7 (referenced in IBC Section 1605.1) or IBC Section 1605.2 which include seismic load effects, and must not exceed the allowable load shown in [Table 2](#). Except as noted in Item 4, above, evaluation of the Hilti fasteners installed in steel base material for use in the design of lateral force resisting systems, such as shear walls and diaphragms, is outside the scope of this report.

## 4.2 Installation:

**4.2.1 General:** The Hilti X-U, X-U 15 and X-P fasteners must be installed in accordance with this report and the Hilti, Inc. published installation instructions. A copy of these instructions must be available on the jobsite at all times during installation. Installation must be limited to dry, interior locations.

Fastener installation requires the use of a low-velocity powder-actuated tool in accordance with Hilti, Inc. recommendations. Installers must be certified by Hilti and have a current, Hilti-issued, operator's license.

**4.2.2 Fastening to Steel:** When installing the Hilti X-U or X-U 15 fastener in steel, the minimum spacing between fasteners must be 1 inch (25.4 mm) and the minimum edge distance must be 1/2 inch (12.7 mm).

**4.2.3 Fastening to Concrete:** Hilti X-U and X-P fasteners must be driven into the concrete after the concrete attains the compressive strength specified in the applicable tables of this report. Minimum spacing between fasteners must be 4 inches (102 mm) and minimum edge distance must be 3 inches (76 mm). Unless noted otherwise in this report, concrete thickness must be a minimum of three times the penetration depth of the fastener.

**4.2.4 Fastening to Hollow Core Precast Concrete Slabs:** Hilti X-U fasteners must be installed into the top or bottom of the hollow core precast concrete slab at the center of a core as shown in [Figure 7](#), and must not make contact with the prestressing steel. The concrete thickness at these locations must be a minimum of 1 3/8 (35 mm) inches thick. Spacing along the length of the slab must be a minimum of 4 inches (102 mm).

**4.2.5 DX-KWIK System:** Installation of the Hilti X-U fastener into normal-weight concrete, using the Hilti DX-KWIK system as an alternate procedure, requires the drilling of a pilot hole using a Special DX-KWIK drill bit (TX-C) supplied by Hilti, Inc., prior to the installation of the fastener with the powder-actuated tool.

**4.2.6 Fastening to Sand-lightweight Concrete-filled Steel Deck Panels:** Installation of Hilti X-U or X-P fasteners in sand-lightweight concrete-filled steel deck panels must comply with [Figures 4](#) through [6](#). Minimum distances from fastener centerline to rolled deck panel flute edges must be as depicted in [Figures 4](#) through [6](#), as applicable.

**4.2.7 Fastening to Concrete Masonry:** Hilti X-U and X-P fasteners must be driven into the concrete masonry after the mortar and grout materials have attained the specified strength. Fasteners must be located in accordance with [Table 6](#).

**4.2.8 Wood Structural Panel Diaphragms:** For horizontal diaphragm applications, wood structural panels must be fastened to steel members with Hilti X-U fasteners at the spacing specified in the approved plans. When used, the optional steel strap is placed on top of the panels and the fasteners are driven through the strap and panel into the supporting steel member. The minimum distance from the centerline of the fasteners to the edge of the panel is  $\frac{3}{8}$  inch (9.5 mm). Fastener penetration and distance to the edge of the supporting steel member must be as described in Section 4.2.2. See [Figure 8](#) for a typical installation detail showing one row of fasteners. The remainder of the diaphragm must be constructed in accordance with the code and the approved plans.

**4.2.9 Use with Treated Lumber:** The Hilti carbon steel fasteners described in [Table 1](#) may be used in contact with fire-retardant-treated wood in dry, interior locations only, in accordance with IBC Section 2304.10.6.4 and Hilti's recommendations. Use of fasteners in contact with preservative-treated wood or fire-retardant-treated wood in exterior applications is outside the scope of this report

## 5.0 CONDITIONS OF USE:

The Hilti X-U, X-U 15 and X-P fasteners described in this report comply with, or are suitable alternatives to what is specified in, those codes listed in Section 1.0 of this report, subject to the following conditions:

- 5.1 The fasteners are manufactured and identified in accordance with this report.
- 5.2 Fastener installation complies with this report and the Hilti, Inc., instructions. In the event of conflict between this report and the Hilti, Inc., published instructions, the more restrictive requirements govern.
- 5.3 Calculations demonstrating that the actual loads are less than the allowable loads described in this report must be submitted to the code official for approval. The calculations must be prepared by a registered design professional where required by the statutes of the jurisdiction in which the project is to be constructed.
- 5.4 For steel-to-steel connections that meet the applicability requirements of Section J5 of AISI S100, calculations demonstrating that the available connection strength has been determined in accordance with Section J5 of AISI S100 and Section 4.1.6 of this report, and equals to or exceeds the applied load, must be submitted to the code official. The calculations must be prepared by a registered design professional where required by the statutes of the jurisdiction in which the project is to be constructed.
- 5.5 Refer to Section 4.1.7 for seismic considerations.
- 5.6 The use of fasteners is limited to installation in uncracked concrete or masonry. Cracking occurs when  $f_t > f_r$  due to service loads or deformations.
- 5.7 Use of fasteners is limited to dry, interior locations, which include exterior walls which are protected by an exterior wall envelope.
- 5.8 Installation must comply with Section 4.2.9 regarding fasteners in contact with preservative-treated and fire-retardant-treated wood.
- 5.9 Installers must be certified by Hilti, Inc., and have a current, Hilti-issued, operator's license.
- 5.10 The Hilti products addressed in this report are manufactured under a quality control program with inspections by ICC-ES.

## 6.0 EVIDENCE SUBMITTED

Data in accordance with the [ICC-ES Acceptance Criteria for Fasteners Power-actuated Fasteners Driven into Concrete, Steel and Masonry Elements \(AC70\)](#), dated July 2024, including seismic load test data in accordance with Annex A of AC70.

## 7.0 IDENTIFICATION

- 7.1 The ICC-ES mark of conformity, electronic labeling, or the evaluation report number (ICC-ES ESR-2269) along with the name, registered trademark, or registered logo of the report holder must be included in the product label.
- 7.2 In addition, each package of fasteners is labeled with the fastener type and size. An “H”, for Hilti, is imprinted on the head of the fastener as shown in [Figures 1, 2 and 3](#).
- 7.3 The report holder’s contact information is the following:

**HILTI, INC.**  
**7250 DALLAS PARKWAY, SUITE 1000**  
**PLANO, TEXAS 75024**  
**(800) 879-8000**  
[www.hilti.com](http://www.hilti.com)

**TABLE 1—FASTENER DESCRIPTION AND APPLICATIONS**

FASTENER <sup>1</sup>	FASTENER DESCRIPTION	SHANK TYPE	SHANK DIAMETER [inch (mm)]	HEAD DIAMETER [inch (mm)]	MAXIMUM POINT LENGTH [inch (mm)]	MINIMUM EFFECTIVE SHANK LENGTH [inch (mm)]	FASTENER COATING	APPLICABLE BASE MATERIAL	APPLICABLE LOAD TABLES
X-U ##	Universal Powder Actuated Fastener	Knurled, straight	0.157 (4.0)	0.323 (8.2)	0.433 (11.0)	See Footnote 2	ASTM B633, SC1, Type III	Steel	2
								Normalweight Concrete (NWC)	3, 4
								Lightweight concrete (LWC) and LWC-filled deck	5
								CMU	6
X-U 15	Powder Actuated Fastener	Knurled, stepped	0.145 (3.7)	0.323 (8.2)	0.413 (10.5)	0.61 (15.5)	ASTM B633, SC1, Type III	Steel	2
X-P ##	Powder Actuated Fastener	Smooth straight	0.157 (4.0)	0.323 (8.2)	0.524 (13.3)	See Footnote 3	ASTM B633, SC1, Type III	NWC	3
								LWC and LWC-filled deck	5
								CMU	6

For SI: 1 inch = 25.4 mm.

<sup>1</sup>## denotes numbers used in fastener designation to represent nominal fastener length in mm, e.g. X-U 27 has a nominal shank length of 27 mm.

<sup>2</sup>For fastener length of 16 mm, the minimum effective shank length is 14.8 mm (0.58 inch). For longer fasteners, the minimum effective shank length can be calculated in terms of the designated length as (##-0.5) in mm and (##-0.5)/25.4 in inches.

<sup>3</sup>The minimum effective shank length can be calculated in terms of the designated length as (##-1) in mm and (##-1)/25.4 in inches.

TABLE 2—ALLOWABLE LOADS FOR FASTENERS DRIVEN INTO STEEL<sup>1,2,6</sup>

FASTENER DESCRIPTION	FASTENER	SHANK DIAMETER (inch)	ALLOWABLE LOADS (lbf)									
			Steel Thickness (inch):		<sup>3</sup> / <sub>16</sub>		<sup>1</sup> / <sub>4</sub>		<sup>3</sup> / <sub>8</sub>		<sup>1</sup> / <sub>2</sub>	
Load Direction:			Tension	Shear	Tension	Shear	Tension	Shear	Tension	Shear	Tension	Shear
Universal Knurled Shank	X-U	0.157	500 <sup>7</sup>	720	775 <sup>7</sup>	720	935	720	900	720	350 <sup>4</sup>	375 <sup>4</sup>
												275 <sup>3</sup>
Universal Knurled Shank	X-U 15	0.145	155	400	230	395	420	450	365 <sup>5</sup>	500 <sup>5</sup>	365 <sup>5</sup>	400 <sup>5</sup>

For SI: 1 inch = 25.4 mm, 1 lbf = 4.45 N; 1 ksi = 6.89 MPa.

<sup>1</sup>Allowable load capacities are based on base steel with a minimum yield strength ( $F_y$ ) of 36 ksi and a minimum tensile strength ( $F_u$ ) of 58 ksi.

<sup>2</sup>The fasteners must be driven to where the point of the fastener penetrates through the steel base material, unless otherwise noted.

<sup>3</sup>Based upon a minimum point penetration of <sup>3</sup>/<sub>8</sub> inch.

<sup>4</sup>Based upon a minimum point penetration of <sup>1</sup>/<sub>2</sub> inch.

<sup>5</sup>Based upon a minimum point penetration of <sup>15</sup>/<sub>32</sub> inch.

<sup>6</sup>Allowable loads are applicable to static and seismic loads in accordance with Section 4.1.

<sup>7</sup>For steel-to-steel connections designed in accordance with Section 4.1.6 for static loads only, the tabulated allowable load may be increased by a factor of 1.25, and the design strength maybe taken as the tabulated allowable load multiplied by a factor of 2.0.

TABLE 3—ALLOWABLE LOADS FOR FASTENERS DRIVEN INTO NORMAL-WEIGHT CONCRETE<sup>1,2,4</sup>

FASTENER DESCRIPTION	FASTENER	SHANK DIAMETER (inch)	MINIMUM EMBEDMENT DEPTH (inches)	ALLOWABLE LOADS (lbf)							
				Concrete Compressive Strength:		2500 psi		4000 psi		6000 psi	
Load Direction:				Tension	Shear	Tension	Shear	Tension	Shear	Tension	Shear
Universal Knurled Shank	X-U	0.157	<sup>3</sup> / <sub>4</sub>	100	125	100	125	105	205	–	–
			1	165	190	170	225	110 <sup>3</sup>	280 <sup>3</sup>	–	–
			<sup>1</sup> / <sub>4</sub>	240	310	280	310	180	425	–	–
			<sup>1</sup> / <sub>2</sub>	275	420	325	420	–	–	–	–
Smooth Shank	X-P	0.157	<sup>3</sup> / <sub>4</sub> <sup>5</sup>	100	155	100	175	105	205	135	205
			1 <sup>5</sup>	165	220	180	225	150	300	150	215
			<sup>1</sup> / <sub>4</sub> <sup>5</sup>	240	310	280	310	180	425	–	–
			<sup>1</sup> / <sub>2</sub> <sup>5</sup>	310	420	–	–	–	–	–	–

For SI: 1 inch = 25.4 mm, 1 lbf = 4.45 N, 1 psi = 6.89 kPa.

<sup>1</sup>Unless otherwise noted, values apply to normal weight cast-in-place concrete. Fasteners must not be driven until the concrete has reached the designated minimum compressive strength.

<sup>2</sup>Unless otherwise noted, concrete thickness must be a minimum of 3 times the embedment depth of the fastener.

<sup>3</sup>This allowable load value for the X-U fastener also applies to normal weight hollow core concrete slabs with  $f'_c$  of 6600 psi and minimum dimensions shown in Figure 7, when installed in accordance with Section 4.2.4.

<sup>4</sup>The fasteners listed in the table above may be used for static load conditions and for the seismic load conditions described in Section 4.1.7, as applicable. The tabulated allowable loads apply to static load conditions. For seismic load conditions, the allowable loads must be limited in accordance with Section 4.1.7, Items 2 and 3, as applicable.

<sup>5</sup>Applies to fastening of cold-formed steel up to 54 mil thick using the X-P 22, X-P 27, X-P 34 and X-P 40 fasteners, respectively, for the <sup>3</sup>/<sub>4</sub>, 1, <sup>1</sup>/<sub>4</sub> and <sup>1</sup>/<sub>2</sub> inch embedment depths.

TABLE 4—ALLOWABLE LOADS FOR FASTENERS DRIVEN INTO NORMAL-WEIGHT CONCRETE USING DX-KWIK<sup>1,2,3,4</sup>

FASTENER DESCRIPTION	FASTENER	SHANK DIAMETER (inch)	MINIMUM EMBEDMENT (inches)	ALLOWABLE LOADS (lbf)			
				Concrete Compressive Strength:		4,000 psi	
Load Direction:				Tension	Shear	Tension	Shear
Universal Knurled Shank	X-U 47 P8 w/ DX-KWIK	0.157	<sup>1</sup> / <sub>2</sub>	395	405	360	570

For SI: 1 inch = 25.4 mm, 1 lbf = 4.45 N, 1 psi = 6.89 kPa.

<sup>1</sup>X-U Fastener is installed using the DX-KWIK drilled pilot hole installation procedure described in Section 4.2.5.

<sup>2</sup>Pilot holes must not be drilled until the concrete has reached the designated minimum compressive strength.

<sup>3</sup>Concrete thickness must be a minimum of 3 times the embedment depth of the fastener.

<sup>4</sup>The fasteners listed in the table above may be used for static load conditions and for the seismic load conditions described in Section 4.1.7, as applicable. The tabulated allowable loads apply to static load conditions. For seismic load conditions, the allowable loads must be limited in accordance with Section 4.1.7, Items 2 and 3, as applicable.

**TABLE 5—ALLOWABLE LOADS FOR FASTENERS DRIVEN INTO MINIMUM  $f'_c = 3000$  psi STRUCTURAL SAND-LIGHTWEIGHT CONCRETE WITH OR WITHOUT METAL DECK<sup>1,6</sup>**

FASTENER DESCRIPTION	FASTENER	SHANK DIAMETER (inch)	MINIMUM EMBEDMENT (inch)	ALLOWABLE LOADS (lbf)							
				Installed into Concrete <sup>4</sup>		Installed Through Metal Deck Panel into Concrete <sup>5</sup>					
Fastener Location:				Tension	Shear	3-inch deep composite floor deck panel <sup>2</sup>		1 1/2-inch deep composite floor deck panel <sup>3</sup>			
Load Direction:						Upper Flute	Lower Flute	Lower Flute	Tension		Lower Flute
				Upper Flute	Lower Flute				Upper Flute	Lower Flute	
Universal Knurled Shank	X-U	0.157	3/4	125	115	130	95	245	95	95	370
			1	205	260	215	155	330	125	125	415
			1 1/4	315	435	295	200	375	–	–	–
			1 1/2	425	475	400	260	430	–	–	–
Smooth Shank	X-P	0.157	3/4 <sup>7</sup>	155	165	130	105	285	140	130	335
			1 <sup>7</sup>	225	300	215	165	340	215	215	385
			1 1/4 <sup>7</sup>	325	445	295	230	375	–	270	465
			1 1/2 <sup>7</sup>	425	480	400	330	365	–	–	–

For SI: 1 inch = 25.4 mm, 1 lbf = 4.45 N, 1 psi = 6.89 kPa.

<sup>1</sup>Fasteners must not be driven until the concrete has reached the designated minimum compressive strength.

<sup>2</sup>The steel deck profile for the 3-inch deep composite floor deck panel has a minimum thickness of 0.0359 inch (0.91 mm) and a minimum  $F_y$  of 50 ksi and a minimum tensile strength of 65 ksi. Lower and upper flute width must be a minimum of 3/8 inches. Figure 4 shows the nominal flute dimensions, fastener locations, and load orientations for the deck panel profile. Sand-lightweight concrete fill above top of steel deck panel must be minimum 3/4 inches thick.

<sup>3</sup>The steel deck profile for the 1 1/2-inch deep composite floor deck panel has a minimum thickness of 0.0359 inch (0.91 mm) and a minimum  $F_y$  of 33 ksi and a minimum tensile strength of 45 ksi. Lower flute and upper flute widths must be a minimum of 1 3/4 inch and 3 1/2 inch, respectively. This deck panel may also be inverted as shown in Figure 6. Figures 5 and 6 show the nominal flute dimensions, fastener locations, and load orientations for the deck panel profile. Sand-lightweight concrete fill above top of steel deck panel must be minimum 2 1/2 inches thick.

<sup>4</sup>Concrete thickness must be a minimum of 3 times the embedment depth of the fastener.

<sup>5</sup>Minimum allowable spacing parallel to the deck flutes is 5.1 inches.

<sup>6</sup>The fasteners listed in the table above may be used for static load conditions and for the seismic load conditions described in Section 4.1.7, as applicable. The tabulated allowable loads apply to static load conditions. For seismic load conditions, the allowable loads must be limited in accordance with Section 4.1.7, Items 2 and 3, as applicable.

<sup>7</sup>Applies to fastening of cold-formed steel up to 54 mil thick using the X-P 22, X-P 27, X-P 34 and X-P 40 fasteners, respectively, for the 3/4, 1, 1 1/4 and 1 1/2 inch embedment depths.

**TABLE 6—ALLOWABLE LOADS FOR FASTENERS DRIVEN INTO CONCRETE MASONRY<sup>3,10</sup>**

FASTENER DESCRIPTION	FASTENER	SHANK DIAMETER (inch)	MINIMUM EMBEDMENT DEPTH (inch)	ALLOWABLE LOADS (lbf)									
				Masonry Type:				Hollow CMU		Grouted CMU			
Fastener Location:				Face Shell <sup>4</sup>		Mortar Joint <sup>5</sup>		Face Shell <sup>4</sup>		Mortar Joint <sup>5</sup>		Top of Grouted Cell <sup>8</sup>	
Load Direction:				Tension	Shear <sup>9</sup>	Tension	Shear <sup>6</sup>	Tension	Shear <sup>9</sup>	Tension	Shear <sup>6</sup>	Tension	Shear <sup>9</sup>
Universal Knurled Shank <sup>1</sup>	X-U	0.157	1	70	85	25	70	215	210	150	190	165	240
Smooth Shank <sup>2</sup>	X-P	0.157	1	70	105	85	70	150	145	150	155 <sup>7</sup>	165	240

For SI: 1 inch = 25.4 mm, 1 lbf = 4.45 N

<sup>1</sup>The tabulated allowable load values are for fasteners installed in masonry conforming to the requirements of Section 3.2.2 of this report. CMUs must be normal weight. Mortar must be Type S.

<sup>2</sup>The tabulated allowable load values are for fasteners installed in masonry conforming to the requirements of Section 3.2.2 of this report. CMUs must be medium weight. Mortar must be Type S.

<sup>3</sup>No more than one low-velocity fastener may be installed in an individual concrete masonry unit cell. The fastener must be installed a minimum of 4 inches from the top, bottom and edges of the wall.

<sup>4</sup>Fastener must be located a minimum of 1 inch from the mortar joints.

<sup>5</sup>Fasteners must not be installed in the head joints. Fasteners installed in the bed joints must be installed a minimum of 8 inches from the end of the wall. Multiple fasteners in a bed joint must be spaced a minimum of 8 inches.

<sup>6</sup>Unless otherwise noted, shear load direction can be horizontal or vertical along the CMU wall plane.

<sup>7</sup>When installed at the intersection of head joint and bed joint (T-joint), the shear load can be applied parallel to the bed joint. When installed away from the T-joint, the shear load direction can be horizontal or vertical along the CMU wall plane.

<sup>8</sup>Fastener located in center of grouted cell installed vertically.

<sup>9</sup>Shear load can be in any direction.

<sup>10</sup>The fasteners listed in the table above may be used for static load conditions and for the seismic load condition described in Item 1 of Section 4.1.7.





FIGURE 1—HILTI X-U FASTENER



FIGURE 2—X-U 15 FASTENER



FIGURE 3—X-P FASTENER

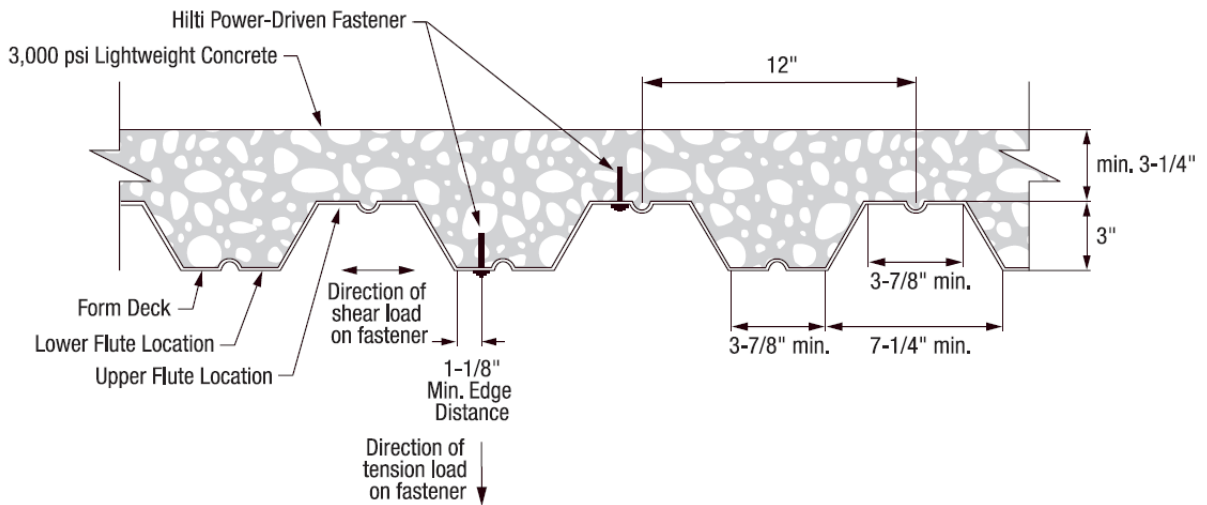

FIGURE 4—HILTI FASTENER LOCATION IN 3-INCH-DEEP COMPOSITE FLOOR DECK PANEL, NORMAL DECK PANEL PROFILE ORIENTATION

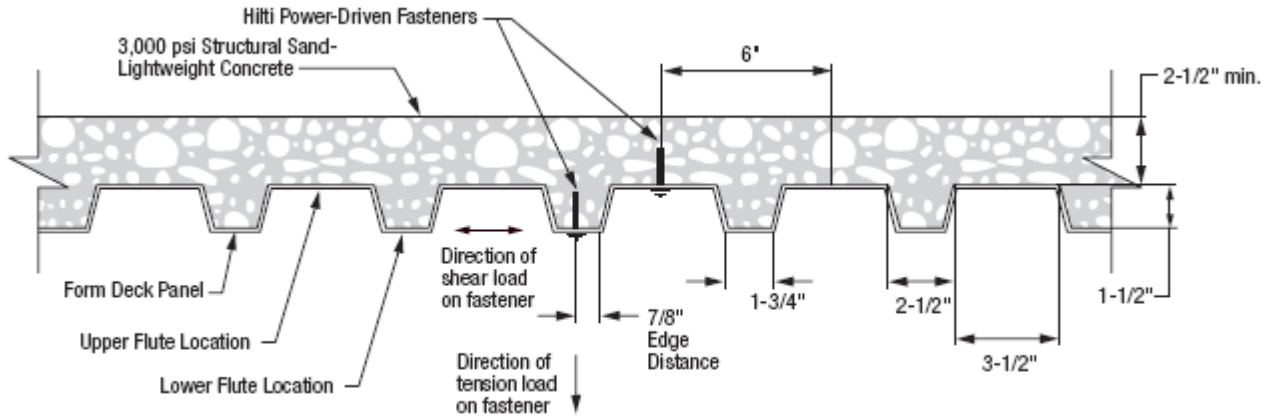

FIGURE 5—HILTI FASTENER LOCATION IN 1 1/2-INCH-DEEP COMPOSITE FLOOR DECK PANEL, NORMAL DECK PANEL PROFILE ORIENTATION

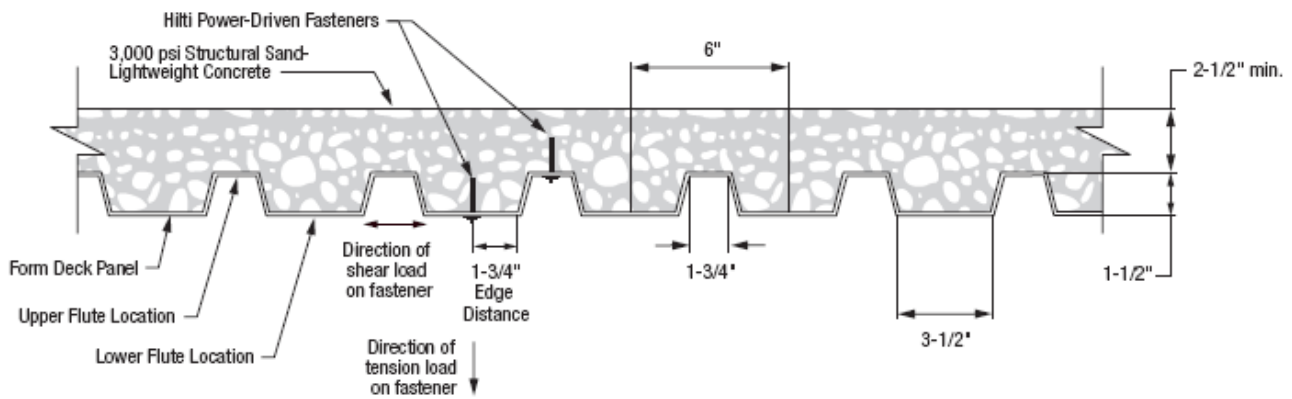

FIGURE 6—HILTI FASTENER LOCATION IN 1 1/2-INCH-DEEP COMPOSITE FLOOR DECK PANEL, INVERTED DECK PANEL PROFILE ORIENTATION

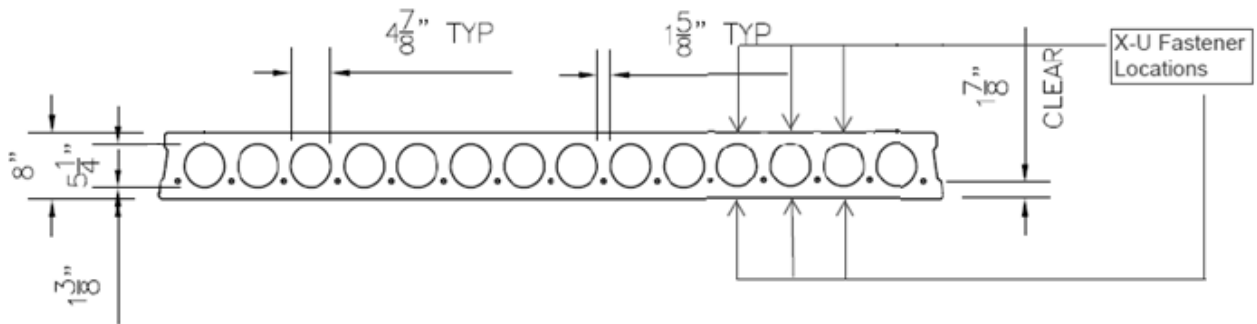
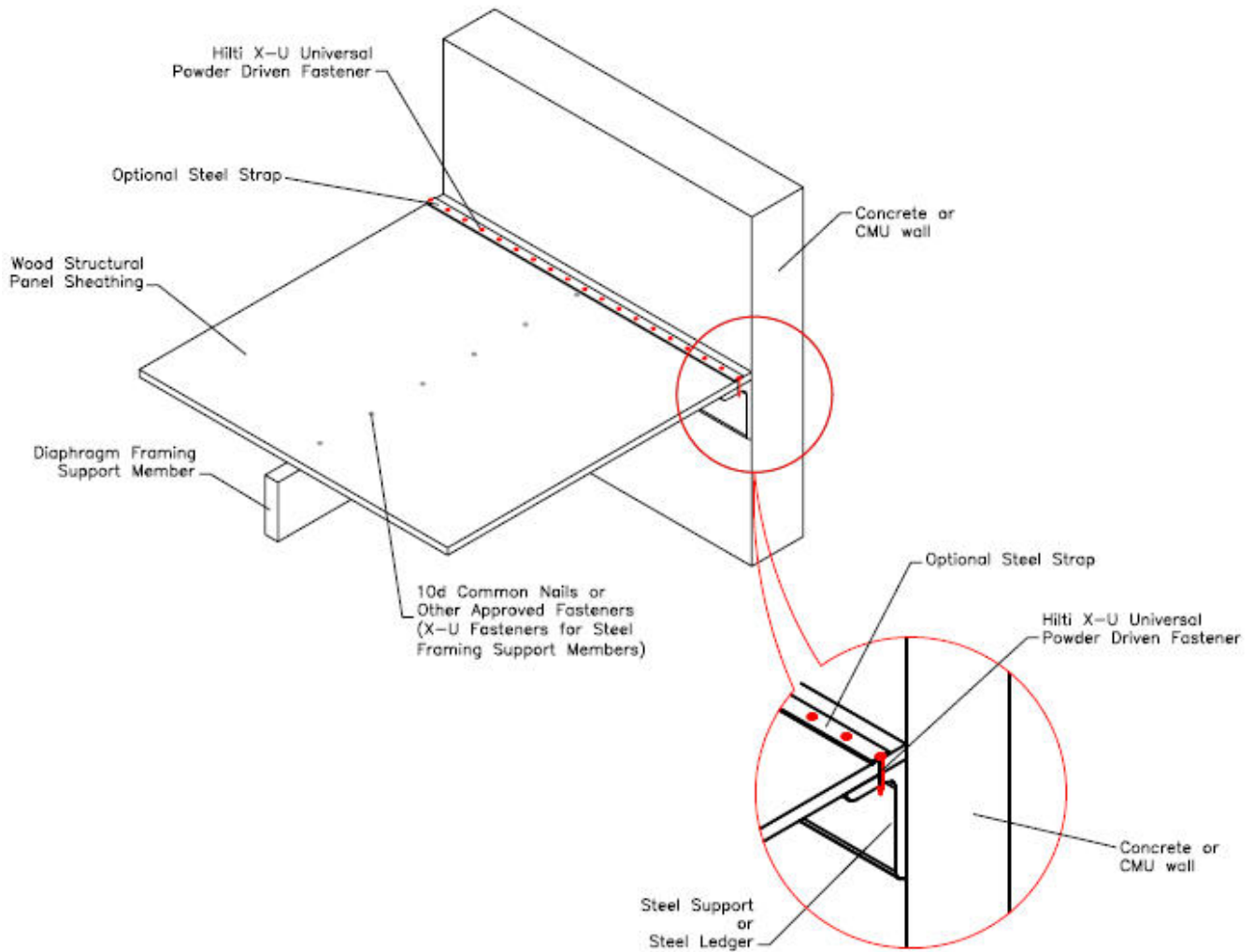

FIGURE 7—HILTI X-U FASTENER LOCATION IN HOLLOW-CORE CONCRETE SLABS



**FIGURE 8—WOOD STRUCTURAL PANEL DECK ATTACHMENT TO STEEL LEDGER WITH HILTI X-U UNIVERSAL POWDER DRIVEN FASTENER**

**TABLE 7—CODE SECTION NUMBER REFERENCE MATRIX**

<b>IBC</b>			
<b>2024 IBC</b>	<b>2021 IBC</b>	<b>2018 IBC</b>	<b>2015 IBC</b>
ASCE 7-22 2.4 (IBC Section 1605.1)	ASCE 7-16/S1 2.4 (IBC Section 1605.1)	1605.3.1	1605.3.1
1605.2	1605.2	1605.3.2	1605.3.2
1901.3	1901.3	1901.3	1901.3
2107	2107	2107	2107
2201.4	2204.1 and 2204.2	2204.1 and 2204.2	2204.1 and 2204.2
2305	2305	2305	2305
2305.1	2305.1	2305.1	2305.1
2306.2	2306.2	2306.2	2306.2
2304.10.6.4	2304.10.6.4	2304.10.5.4	2304.10.5.4
<b>AISI S100 Edition and Section Number</b>			
2016(2020) w/S2-20 J5	2016(2020) w/S2-20 J5	2016 J5	2012 E5
2016(2020) w/S2-20 J5.2	2016(2020) w/S2-20 J5.2	2016 J5.2	2012 E5.2
2016(2020) w/S2-20 J5.2.1	2016(2020) w/S2-20 J5.2.1	2016 J5.2.1	2012 E5.2.1
2016(2020) w/S2-20 J5.2.3	2016(2020) w/S2-20 J5.2.3	2016 J5.2.3	2012 E5.2.3
2016(2020) w/S2-20 J5.3	2016(2020) w/S2-20 J5.3	2016 J5.3	2012 E5.3
2016(2020) w/S2-20 J5.3.1	2016(2020) w/S2-20 J5.3.1	2016 J5.3.1	2012 E5.3.1
2016(2020) w/S2-20 J5.3.2	2016(2020) w/S2-20 J5.3.2	2016 J5.3.2	2012 E5.3.2
2016(2020) w/S2-20 J5.3.3	2016(2020) w/S2-20 J5.3.3	2016 J5.3.3	2012 E5.3.3
2016(2020) w/S2-20 J5.3.4	2016(2020) w/S2-20 J5.3.4	2016 J5.3.4	2012 E5.3.4
2016(2020) w/S2-20 J5.3.5	2016(2020) w/S2-20 J5.3.5	2016 J5.3.5	2012 E5.3.5
<b>Other Referenced Standards</b>			
ASCE 7-22 Table 13.1-1	ASCE 7-16 w/S1 13.1.4	ASCE 7-16 13.1.4	ASCE 7-10 w/S1 13.1.4
TMS 402-22 8.1.4	TMS 402-16 8.1.3	TMS 402-16 8.1.3	TMS 402-13 8.1.3
.AWC NDS-2024 11.3	AWC NDS-2018 11.3	AWC NDS-2018 11.3	AWC NDS-2015 11.3
AWC NDS-2024 12.2.5	AWC NDS-2018 12.2.5	AWC NDS-2018 12.2.5	n/a – use AWC NDS-2018 12.2.5
AWC SDPWS-2021 4.2.7	AWC SDPWS-2021 4.2.7	AWC SDPWS-2015 4.2.6	AWC SDPWS-2015 4.2.6
<b>IRC</b>			
<b>2024 IRC</b>	<b>2021 IRC</b>	<b>2018 IRC</b>	<b>2015 IRC</b>
R301.1.3	R301.1.3	R301.1.3	R301.1.3
R402.2	R402.2	R402.2	R402.2

**DIVISION: 03 00 00—CONCRETE**  
**Section: 03 15 00—Concrete Accessories**  
**Section: 03 16 00—Concrete Anchors**

**DIVISION: 04 00 00—MASONRY**  
**Section: 04 05 19.16—Masonry Anchors**

**DIVISION: 05 00 00—METALS**  
**Section: 05 05 23—Metal Fastenings**

**DIVISION: 06 00 00—WOOD, PLASTICS AND COMPOSITES**  
**Section: 06 05 23—Wood, Plastic, and Composite Fastenings**

**REPORT HOLDER:**

HILTI, INC.

**EVALUATION SUBJECT:**

HILTI LOW-VELOCITY X-U AND X-U 15 UNIVERSAL FASTENERS AND X-P CONCRETE FASTENERS

**1.0 REPORT PURPOSE AND SCOPE****Purpose:**

The purpose of this evaluation report supplement is to indicate that Hilti Low-Velocity X-U and X-U 15 Universal Fasteners and X-P Concrete Fasteners, described in ICC-ES evaluation report [ESR-2269](#), have also been evaluated for compliance with the codes noted below as adopted by the Los Angeles Department of Building and Safety (LADBS).

**Applicable code editions:**

- 2023 *City of Los Angeles Building Code* ([LABC](#))
- 2023 *City of Los Angeles Residential Code* ([LARC](#))

**2.0 CONCLUSIONS**

The Hilti Low-Velocity X-U and X-U 15 Universal Fasteners and X-P Concrete Fasteners, described in Sections 2.0 through 7.0 of the evaluation report [ESR-2269](#), comply with the LABC Chapter 19, 21, 22, 23 and the LARC, and are subject to the conditions of use described in this supplement.

**3.0 CONDITIONS OF USE**

The Hilti Low-Velocity X-U and X-U 15 Universal Fasteners and X-P Concrete Fasteners described in this evaluation report supplement must comply with all of the following conditions:

- All applicable sections in the evaluation report [ESR-2269](#).
- The design, installation, conditions of use and identification of the fasteners are in accordance with the 2021 *International Building Code*® (2021 IBC) provisions noted in the evaluation report [ESR-2269](#).
- The design, installation and inspection are in accordance with additional requirements of LABC Chapters 16 and 17, as applicable.
- Under the LARC, an engineered design in accordance with LARC Section R301.1.3 must be submitted.
- The allowable strength values listed in the evaluation report are for the connection of the fasteners to normalweight concrete, lightweight concrete with or without metal deck, steel, and masonry. The connection between the fasteners and the connected members must be checked for capacity (which may govern).

This supplement expires concurrently with the evaluation report, reissued February 2025.

**DIVISION: 03 00 00—CONCRETE**  
Section: 03 15 00—Concrete Accessories  
Section: 03 16 00—Concrete Anchors

**DIVISION: 04 00 00—MASONRY**  
Section: 04 05 19.16—Masonry Anchors

**DIVISION: 05 00 00—METALS**  
Section: 05 05 23—Metal Fastenings

**DIVISION: 06 00 00—WOOD, PLASTICS AND COMPOSITES**  
Section: 06 05 23—Wood, Plastic, and Composite Fastenings

## REPORT HOLDER:

HILTI, INC.

## EVALUATION SUBJECT:

**HILTI LOW-VELOCITY X-U AND X-U 15 UNIVERSAL FASTENERS AND X-P CONCRETE FASTENERS**

## 1.0 REPORT PURPOSE AND SCOPE

### Purpose:

The purpose of this evaluation report supplement is to indicate that the Hilti Low-Velocity X-U and X-U 15 Universal and X-P Concrete Powder Driven Fasteners, described in ICC-ES evaluation report ESR-2269, have also been evaluated for compliance with the codes noted below.

### Applicable code editions:

- 2023 Florida Building Code—Building
- 2023 Florida Building Code—Residential

## 2.0 CONCLUSIONS

The Hilti Low-Velocity X-U and X-U 15 Universal and X-P Concrete Powder Driven Fasteners, described in Sections 2.0 through 7.0 of the evaluation report ESR-2269, comply with the *Florida Building Code—Building* and the *Florida Building Code—Residential*, with the replacement of the referenced ASCE 7 edition as noted below. The design requirements shall be determined in accordance with the *Florida Building Code—Building* or the *Florida Building Code—Residential*, as applicable. The installation requirements noted in ICC-ES evaluation report ESR-2269 for the 2021 *International Building Code*® meet the requirements of the *Florida Building Code—Building* or the *Florida Building Code—Residential*, as applicable.

References to ASCE 7-16/S1 in ESR-2269 shall be replaced with ASCE 7-22. This is necessary as the 2023 *Florida Building Code—Building* references ASCE 7-22 and the 2021 *International Building Code*® references ASCE 7-16/S1.

Use of the Hilti Low-Velocity X-U and X-U 15 Universal and X-P Concrete Powder Driven Fasteners has also been found to be in compliance with the High-Velocity Hurricane Zone provisions of the *Florida Building Code—Building* and the *Florida Building Code—Residential* under the following conditions:

- The use of the Hilti Low-Velocity X-U and X-U 15 Universal and X-P Concrete Powder Driven Fasteners as a means of attachment for wood blocking, as defined in Section 2330.1.10 of the *Florida Building Code—Building*, is prohibited. Attachment of wood structural panel diaphragms to supporting steel framing members, as described in the evaluation report ESR-2269, is acceptable.
- The fasteners have not been evaluated for use as cast-in-place anchors for compliance with the High-Velocity Hurricane

Zone provisions, and this use is outside the scope of this supplement.

For products falling under Florida Rule 61G20-3, verification that the report holder's quality assurance program is audited by a quality assurance entity approved by the Florida Building Commission for the type of inspections being conducted is the responsibility of an approved validation entity (or the code official, when the report holder does not possess an approval by the Commission).

This supplement expires concurrently with the evaluation report, reissued February 2025.